

**TELESCOPIC**

# **PERSONNEL CAGES**

**TPC & PSC**





## TPC & PSC – TELESCOPIC PERSONNEL CAGES

### Function TPC PSC

- Pick-up by the master spreader (same procedure as for a standard box), telescoping to the desired position (20 – 45 ft).
- Each gondola is manned with a lasher. The lashers communicate with one another and with the crane operator via radio.
- The STS crane moves the personnel cage from the ship's landside over the container stack to be worked on. The gondolas are now on this stack's right and left-hand side.
- With the PSC, the lashers are in the right position to easily reach the twistlocks to be opened. Operating the TPC, the lashers lower their gondolas – independent from each other – to the position from which they can easily reach the TWLs of the container stack's top layer.
- Moving slowly along the containers (with short stops where necessary), the lashers unlock the twistlocks while trolleying by.
- After having arrived at the stack's seaside, the PSC's operation cycle is finished. In TPC gondolas, the lashers lower their gondolas to the level of the second container layer and unlock these twistlocks on their way back.
- After having finished their work, the lashers exit the gondolas and the TPC's vertical telescopes retract due to the spreader's weight. The horizontal telescope is retracted by the master spreader which moves the personnel cage to the desired position.
- The PSC can be stored everywhere on flat ground, whilst the TPC is kept at a storing place intended for this purpose (c.f. "Requirements").

### Product Benefits TPC PSC

- No need for internal or external power supply; the hydraulic system of the TPC solely serves the safe lowering of the gondolas.
- No need for extensions or modifications on the spreader, very flexible application regardless of the spreader brand; no interference with warranty issues of third parties.
- Compact storage dimensions due to the telescopic main beam (20ft width) enables compact storage on STS crane, particularly for the TPC with its vertical telescopes.
- The TPC allows fewer empty runs of the STS crane due to handling of two container layers in one operation step.
- Significantly increased occupational safety: the lashers work in an area which is protected all around, even against falling objects.
- Lashers adopt ergonomic posture: the gondola puts them at grip / eye level with their work.
- These machines are also ideal implements for all kinds of disturbances / problems on container stacks (such as f.e. blocked or frozen twistlocks). Maintenance personnel can take tools, welding torches etc. with them in the gondola.
- Dimensions of the gondolas are compatible with almost all ship types.
- Sturdy and stable construction, designed for the rough operating conditions.
- A world-wide network of sales partners guarantees reliable service and quick spare part deliveries.





## TPC - HORIZONTALLY & VERTICALLY TELESCOPIC PERSONNEL CAGE

### TPC-S2 - the all-rounder on deck main dimensions

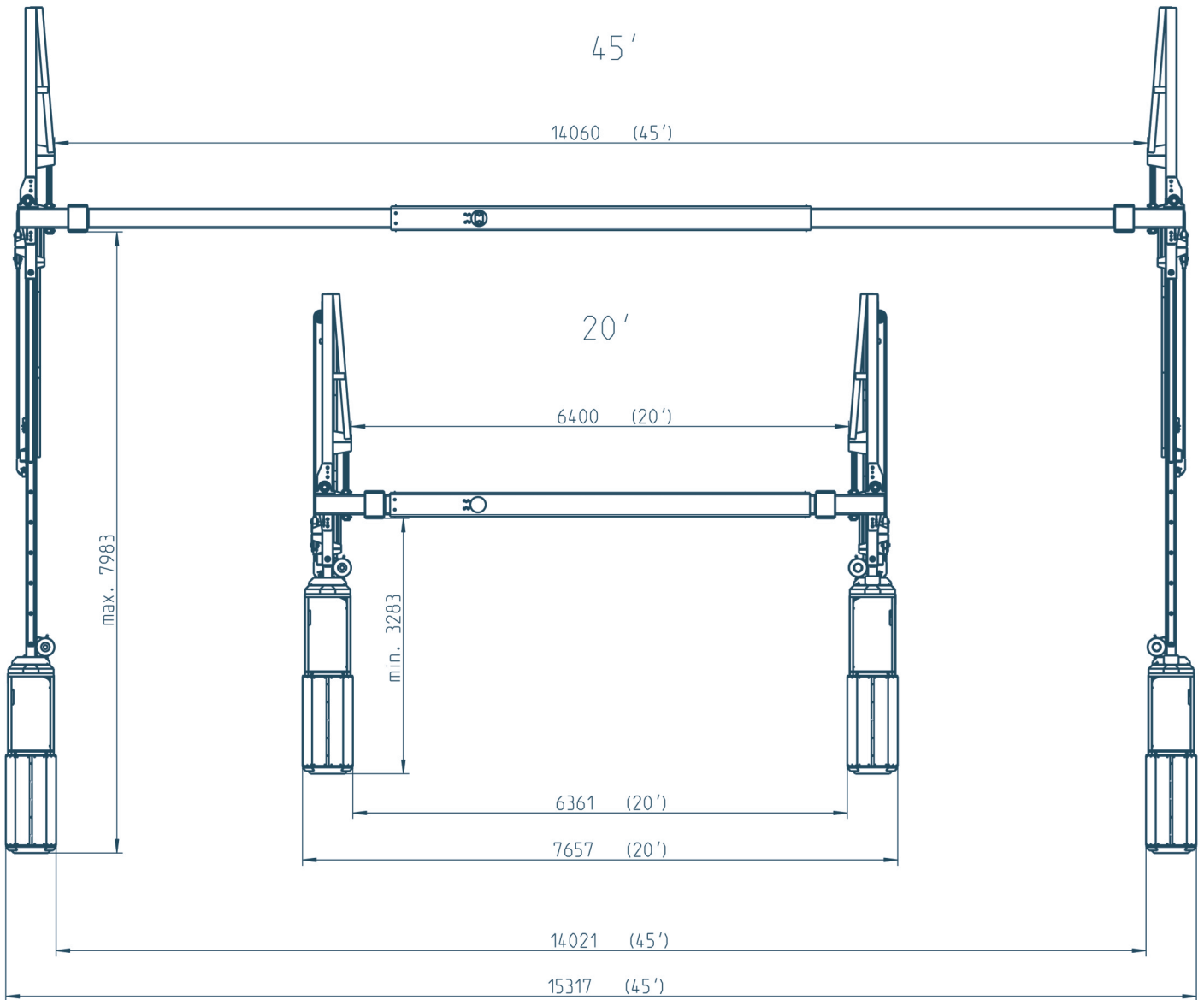



## TPC - HORIZONTALLY & VERTICALLY TELESCOPIC PERSONNEL CAGE

### TPC-S2 - the all-rounder on deck

#### Side view

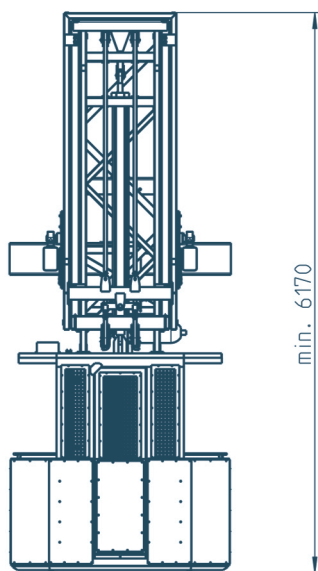
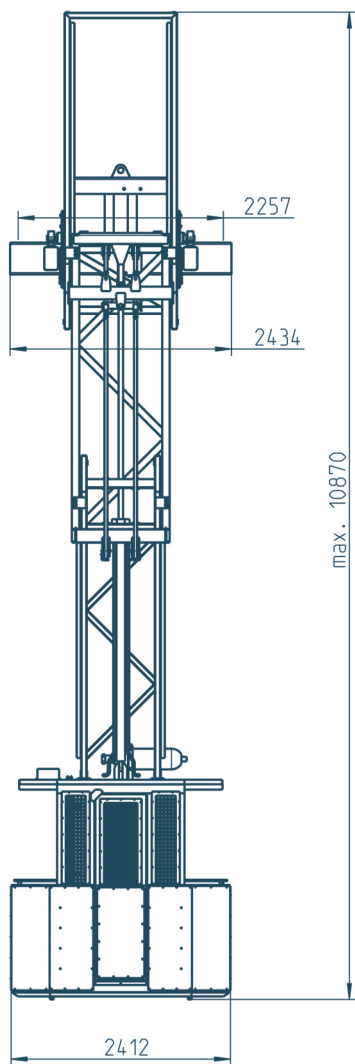

#### Gondola

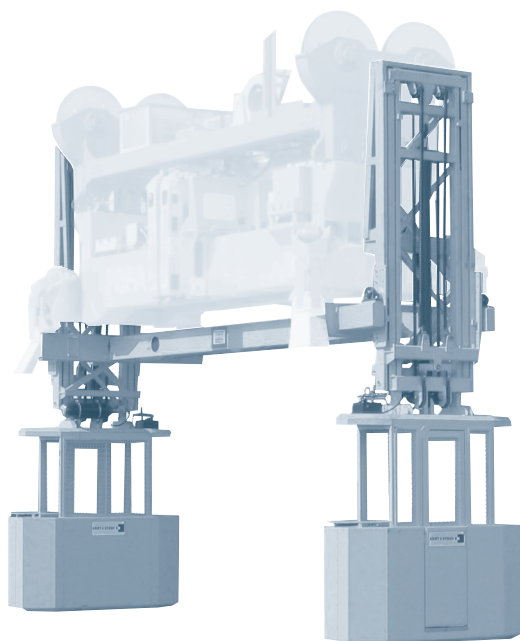
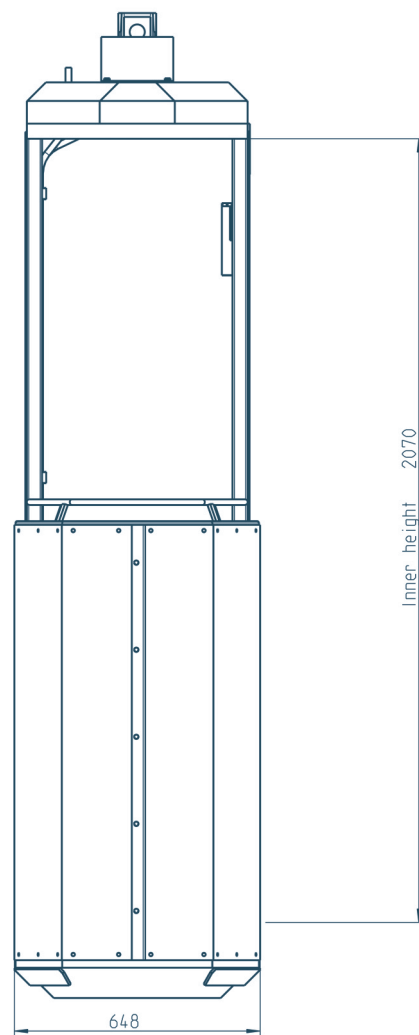



## TPC – HORIZONTALLY & VERTICALLY TELESCOPIC PERSONNEL CAGE

### Structure

- St 52-3 steel construction
- Consists of one horizontal and two vertical telescopes with two gondolas.
- Gondolas with self-closing doors as well as security devices for protection from falling objects and getting hands and feet caught.
- Safe telescoping of the gondolas due to hydraulic brake (filling capacity 25 liters per side) operated from within the gondola.
- Steel construction sand-blasted.
- Coating with rust inhibiting primer – double top coating with a thickness of up to 200µm.

### Requirements

- The spreader's four twistlocks have to be provided with a mechanical security lock preventing unlocking under load.
- The TPC's safe pick-up by the spreader has to be recognizable by the crane operator through guard pins on the spreader and position indicators of the spreader twistlocks.
- The spreader has to be capable of telescoping in spite of the TPC's additional weight.
- There has to be suitable equipment for the radio communication between the lashers and the crane operator.
- The TPC gondola must not be placed on any surface other than the parking position provided by its operator (e.g. a 20' container with appropriate substructure).

### Technical Data

Net weight:	5.2 t
Temperature range:	- 20°C up to 55°C
Net Load:	250 kg per gondola

### Regulations

- EC machinery guidelines (2006/42/EY)
- EN ISO 12100 - 1:2005 and EN ISO 12100 - 2:2005
- DIN EN 1808 Safety Requirements on Suspended Access Equipment
- Steel construction DIN 15018 Part 1 and 18800 Part 2
- Stability DIN 4114



## PSC - TELESCOPIC PERSONNEL CAGE

### PSC - good value for money main dimensions

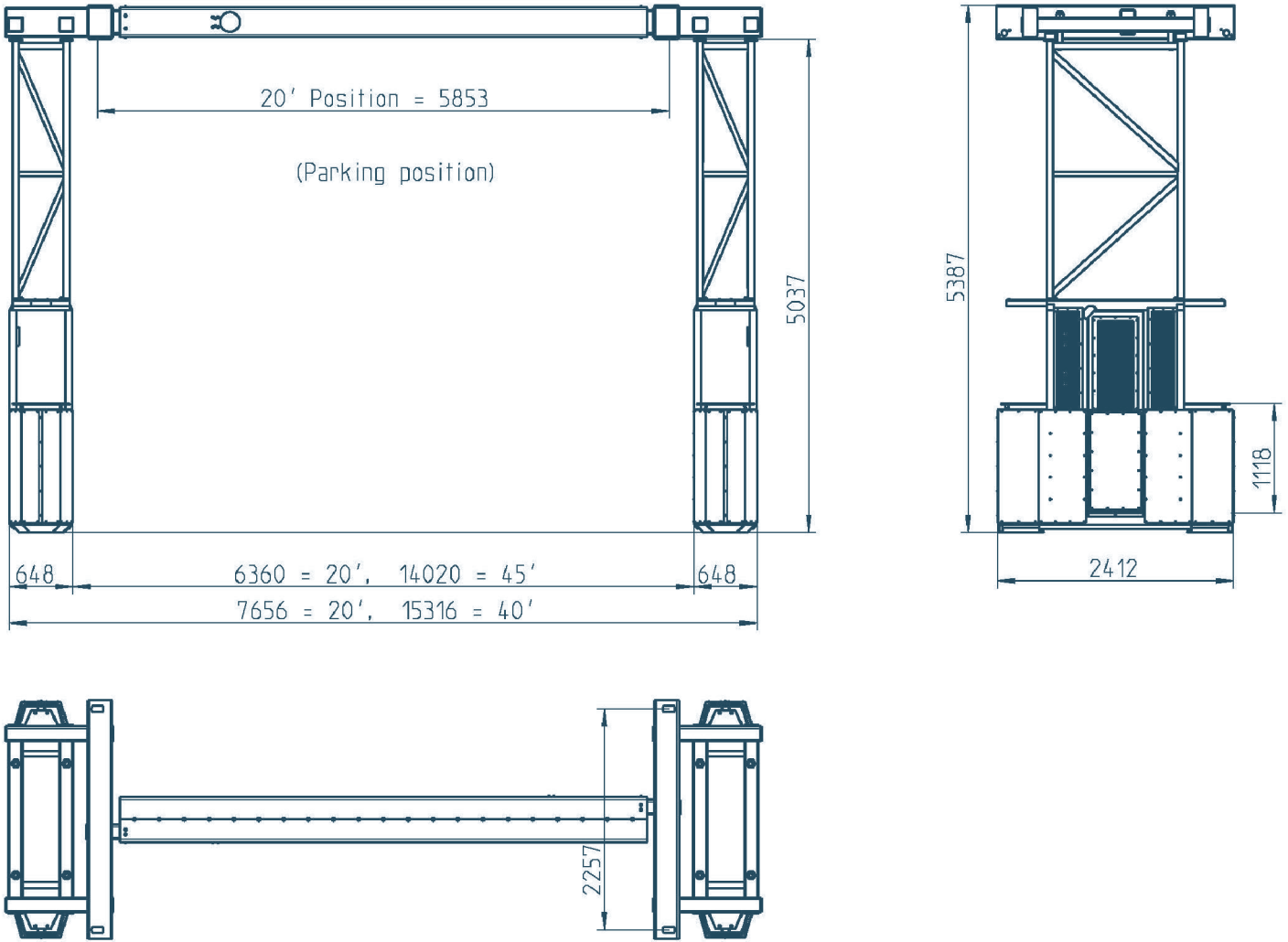



## PSC – TELESCOPIC PERSONNEL CAGE

### Structure

- Sturdy St 52-3 steel construction
- Steel construction sand blasted
- Consists of a main beam, expandable from 20ft to 45ft, fitted with one gondola at each side
- Coating with rust inhibiting primer – double top coating with a thickness up to 200µm
- Gondolas with self closing doors as well as security devices for protection from falling objects and getting hands and feet caught

### Requirements

- The master spreader's four twistlocks have to be provided with a mechanical security lock preventing unlocking under load
- The spreader has to be capable of telescoping in spite of the PSC's additional weight
- The PSC's safe pick-up by the spreader has to be recognizable by the crane operator through guard pins on the spreader and position indicators of the spreader twistlocks
- There has to be suitable equipment for the radio communication between the lashers and the crane operator
- Other than the TPC, the PSC can be stored anywhere on flat ground. No special parking device is required

### Technical Data

Net weight:	4.3 t
Temperature range:	- 20°C up to 55°C
Net Load:	250 kg per gondola

### Regulations

EC machinery guidelines (2006/42/EY)

EN ISO 12100 - 1:2005 and  
EN ISO 12100 - 2:2005

DIN EN 1808 Safety Requirements on  
Suspended Access Equipment

Steel construction DIN 15018 Part 1 and  
18800 Part 2

Stability DIN 4114

## About us

In 2015 MWB, a German high quality supplier for special machinery equipment in the field of intralogistics, took over the product range of Sort + Store. For many years Sort + Store's spreader attachments and safety cages have been famous for their reliability and robustness that is both necessary to meet the daily requirements in the field of container handling.

### Advanced Container Handling

Throughout the world modern container terminals strive for quicker cargo handling and, simultaneously, enhanced occupational safety. The fully automatic overheight frames and telescopic lashing gondolas offered by MWB succeed in providing both.

They help to automate handling processes carried out manually up to now and set standards in terms of ergonomics.

A close co-operation between development and user from the very beginning of the design of new handling equipment is our top priority and leads to the creation of market-oriented products. Furthermore, we are in steady contact with the harbors' operations and maintenance divisions. We take all kinds of input and integrate it into our product development in order to constantly optimize the features of our products.

### German engineering

In our eyes, the most important characteristics of MWB products are sturdiness and durability. The applications in container handling and the extreme productivity requirements container terminals have to meet demand equipment that is conceived especially for this working environment.

That's why we have decided to offer mechanical engineering "made in Germany".

Therefore, we are capable of delivering a consistently high quality level. Equipment still working flawlessly after ten years of service proves this decision right.

### Protected connections

MWB equipment is compatible with almost 100% of the container handling devices used in large sea harbors world-wide – regardless of brands. Many of the renowned operators count on this flexibility: e.g. MAERSK/Sealand, P&O Ports, PSA, Maher, Axis, Patrick Stevedores and, of course, the German groups EUROGATE and HHLA.

We are proud of the confidence our customers show in us and feel obligated to create "protected connections" in the future as well.

### TOF



**Telescopic  
Overheight  
Frame**

### OHF



**Fixed  
Overheight  
Frame**



**MWB GmbH**  
**Siemensstrasse 15**  
**D-84109 Wörth/Isar**  
**Germany**

**Phone: +49 (0) 8702 94664-40**  
**Fax: +49 (0) 8702 94664-41**  
**email: [info@mwbgbmh.com](mailto:info@mwbgbmh.com)**  
**web: [www.mwbgbmh.com](http://www.mwbgbmh.com)**

Technical specifications are subject to change without prior notice.

MWB GmbH hold worldwide patents on all products.

© 2015 MWB GmbH